

# SMMI-FLEX

Fixed height mobile stand  
*Soporte de ruedas fijo en altura*

**INSTALLATION MANUAL**  
*MANUAL DE INSTALACIÓN*

**traulux**



No seguir estas instrucciones puede provocar accidentes y fallos en el producto.  
Failure to follow these instructions may result in accidents or the product being damaged.

## INSTRUCCIONES DE SEGURIDAD / SAFETY INSTRUCTIONS

### GENERAL:



Este producto no se ha diseñado para el uso por parte de niños pequeños.  
This product is not intended for use by young children without supervision.



Si ve fallos o daños en el producto, no proceda a su instalación.  
If there is visible damage to the product, do not install it.



El producto está fabricado con chapa de acero decapado de espesores 1,50; 2,00 y 3,00 mm y con perfiles de tubo de acero de espesores 1,50; 2,00 y 3,00 mm.  
This product has been manufactured with steel tubes & sheets (1,50; 2,00 & 3,00 mm thickness).



Este producto se ha diseñado para el uso en interiores con temperaturas ambiente entre 10°C y 40°C.  
For indoor use only (+10°-40°)

- Asegúrese de haber seguido este manual de instrucciones.  
Make sure that the system has been installed following this manual.

- No cargar más peso del indicado en este manual de instalación. A efectos de certificación y pruebas de carga en el proceso de evaluación de riesgos, los coeficientes de seguridad utilizados han sido:  
- SMI-FLEX & SMMI-FLEX: Cs 1,10

Don't overload the system in relation to the maximum weight capacity stated on this installation guide. These are the security and safety coefficients used when certifying the systems and running the loading tests:  
- SMI-FLEX & SMMI-FLEX: Cs 1,10

Durante el uso / During operation:



- Asegúrese que los cables no se dañan o pellizcan.  
Take care that cables are not damaged.  
- Desconectar de la corriente si se necesita mover el sistema.  
Unplug the mains cable on mobile equipment before moving it.

Uso incorrecto / Misuse:



En los modelos móviles con ruedas, tenga siempre en mente la longitud de las patas de la base de suelo ya que existe un riesgo de tropiezo.  
While using a trolley system, be always aware of the potential risk of tumble with the base legs.

Mantenimiento / Maintenance:



- Desconecte el sistema de la corriente antes de proceder a su limpieza.  
Unplug the mains cable before proceeding with clearing process.  
- Los productos de limpieza o desinfectantes utilizados no deben ser excesivamente alcalinos o ácidos (pH 6-8).  
Cleaners & disinfectants must not be highly alkaline or acidic (pH 6-8).

### 1. Duration of the Warranty

CHARMEX INTERNACIONAL warrants that all its products are free from defects in materials and workmanship for a period of sixty (60) months (5 years) from the date of delivery to the distributor.

### 2. Warranty Coverage

This warranty covers:

1. Manufacturing defects.
2. Failures in materials.

CHARMEX INTERNACIONAL, at its discretion, will repair or replace any component of all its products that are proven to be defective due to improper materials or workmanship during the warranty period, but you must pay any related labour cost

### 3. Exclusions from the Warranty

This warranty does not cover:

1. Damage caused by misuse, abuse, neglect, accidents, or unauthorized modifications.
2. Damage caused by improper installation or failure to follow instructions in the user manual.
3. Cosmetic damage, including scratches, dents, and similar damage.
4. Any product with the serial number altered or removed.

### 4. After Sale Service Procedure

In the event of a defect covered by this warranty, the affected party must follow these steps to make a claim:

1. Contact: The distributor must contact CHARMEX INTERNACIONAL's customer service department via:

- Email: [charmex@charmex.net](mailto:charmex@charmex.net)
- Telephone: +34 93 303 66 20

2. Documentation: Provide the following documentation:

- Proof of purchase (invoice or receipt).
- Detailed description of the defect.
- Photos or videos showing the problem.

7. Product Shipping: If requested, the distributor must send the defective product to our service address at his own expense

- Service Address: C/ Maresme 103-105 08019 Barcelona
- CHARMEX INTERNACIONAL will cover the shipping costs of returning the defective product within the warranty period.

### 5. Repair or Replacement

CHARMEX INTERNACIONAL, at its discretion, will repair or replace the defective product or part at no additional cost to the dealer. If the model in question is no longer available, CHARMEX INTERNACIONAL reserves the right to replace it with a similar model. After repairment or replacement, CHARMEX INTERNACIONAL will ship the new product or part to the distributor at CHARMEX INTERNACIONAL's expenses

### 6. Limitation of Liability

CHARMEX INTERNACIONAL's liability is limited solely to the cost of repairing or replacing the defective product, and does not include any incidental or consequential damages. This warranty does not affect other contractual rights agreed between CHARMEX INTERNACIONAL and the distributor.

### 7. Non-Disclosure Agreement

All information relating to this warranty agreement must be treated confidentially and must not be disclosed to any third party without the prior written consent of both parties.

CHARMEX INTERNACIONAL appreciates your collaboration and trust in our products

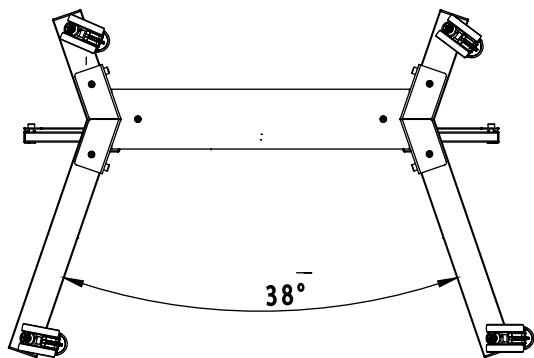
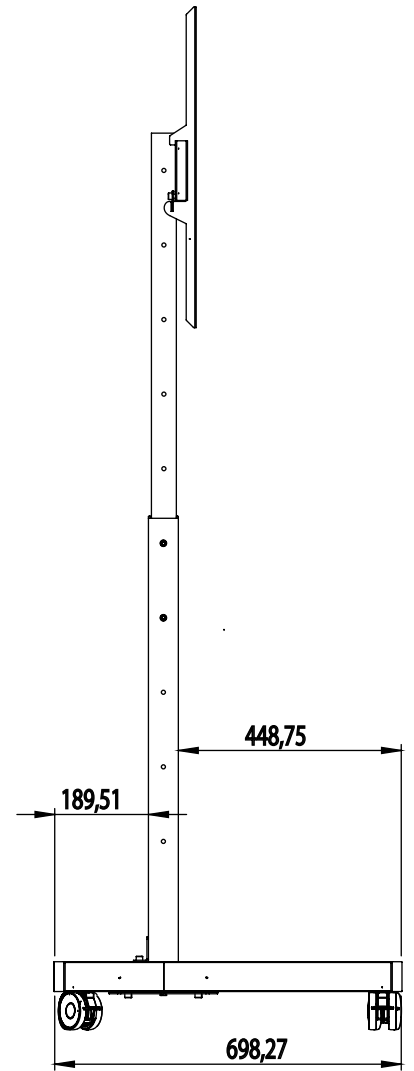
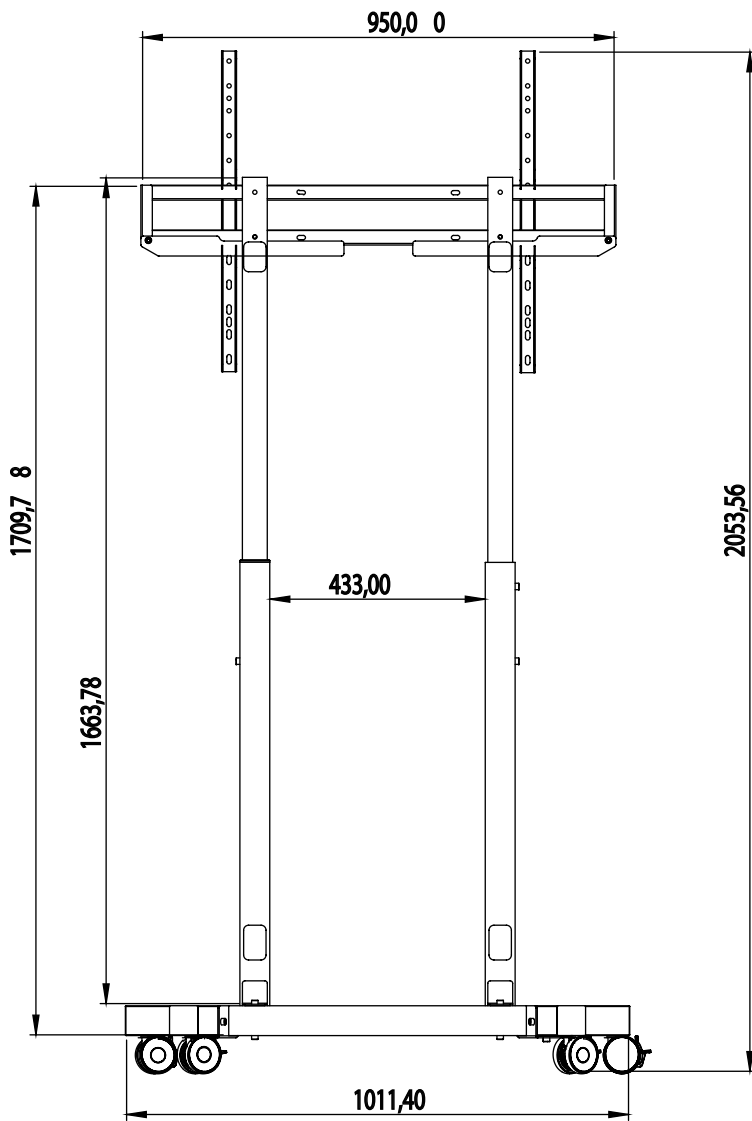

55-98"



100 MAX

**CONTENIDO/CONTENTS/CONTENUTO/SISÄLLYS/CONTENU:**

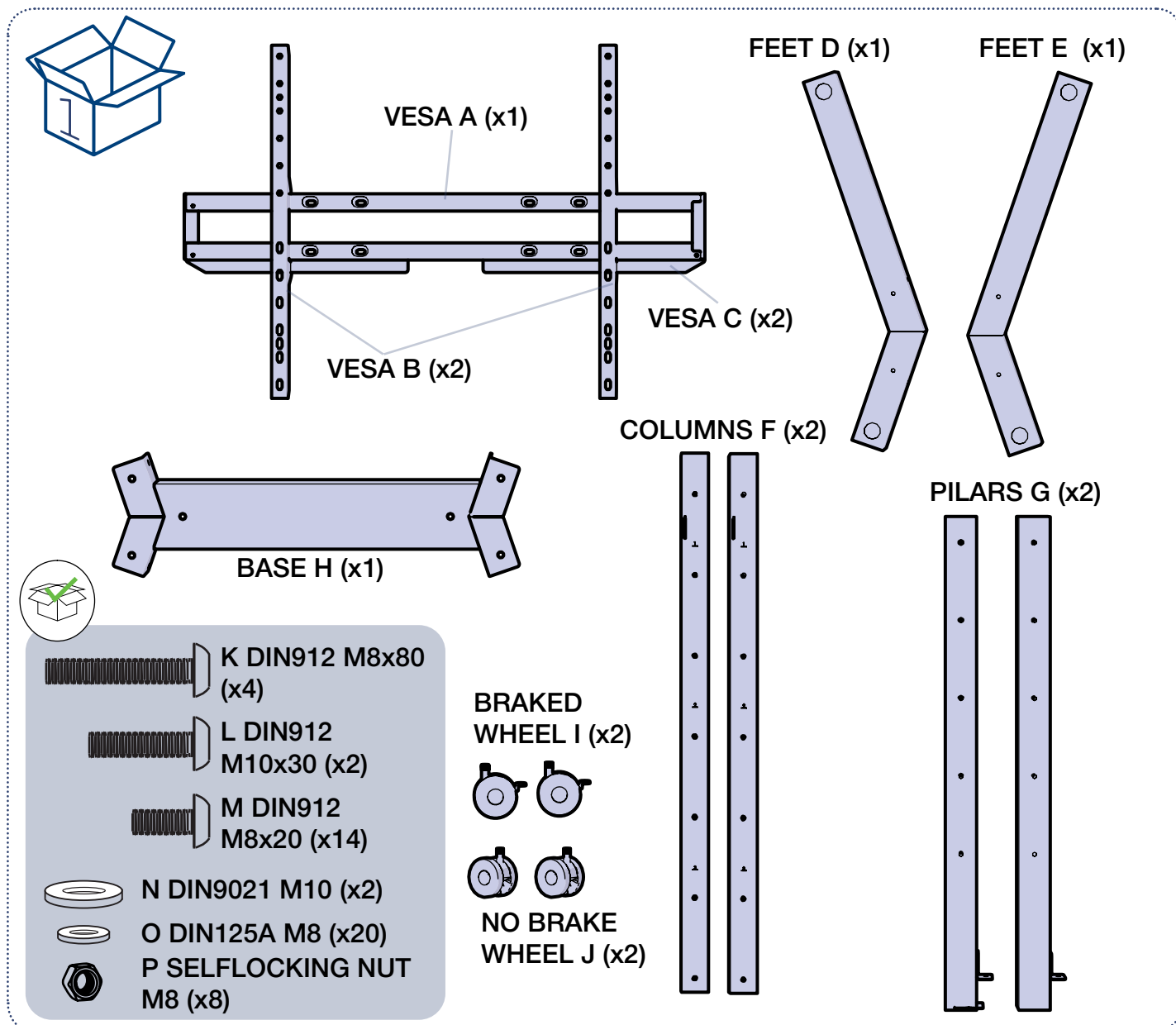

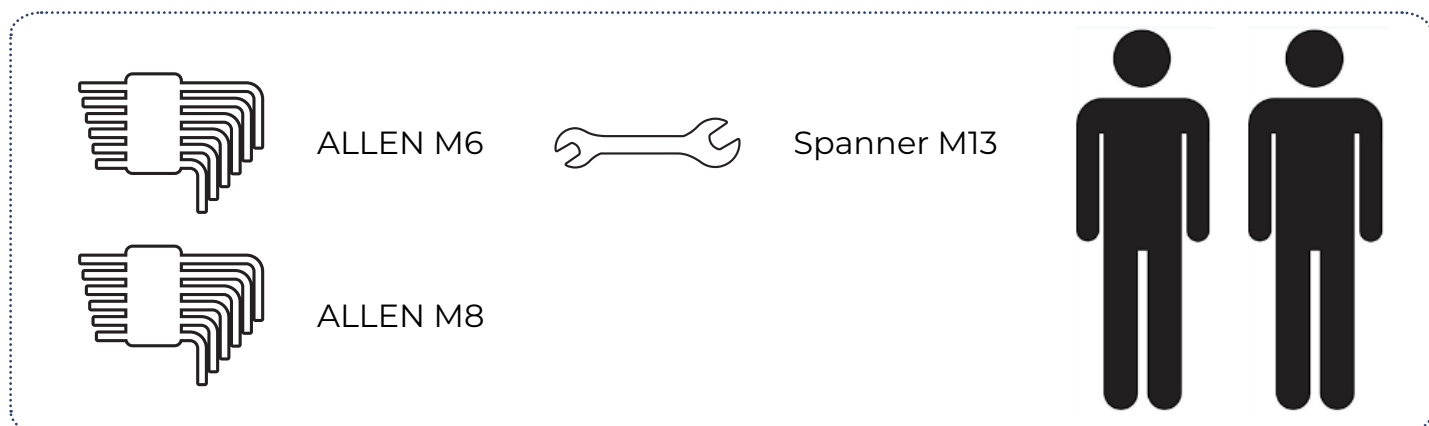

**HERRAMIENTAS NECESARIAS/TOOLS NEEDED/ATTREZZI NECESSARI/TARPEELLISET TYÖKALUT/OUTILS NÉCESSAIRES:**

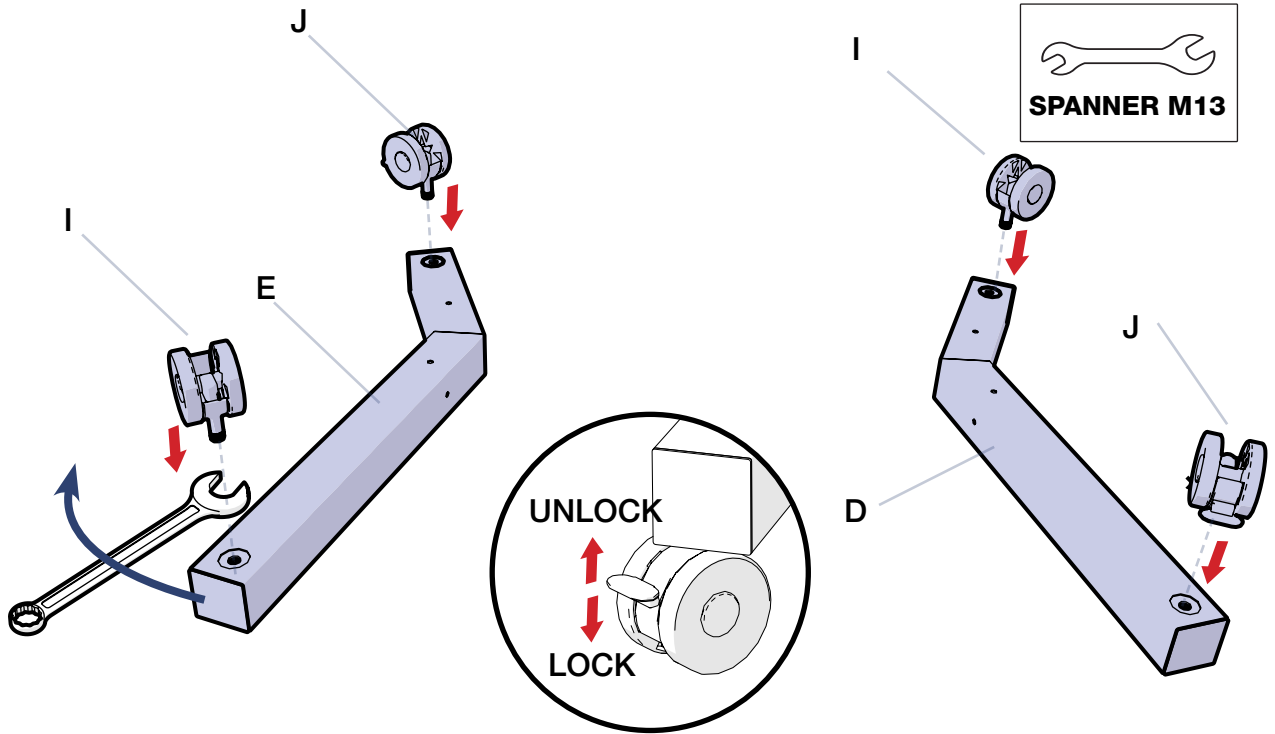

1





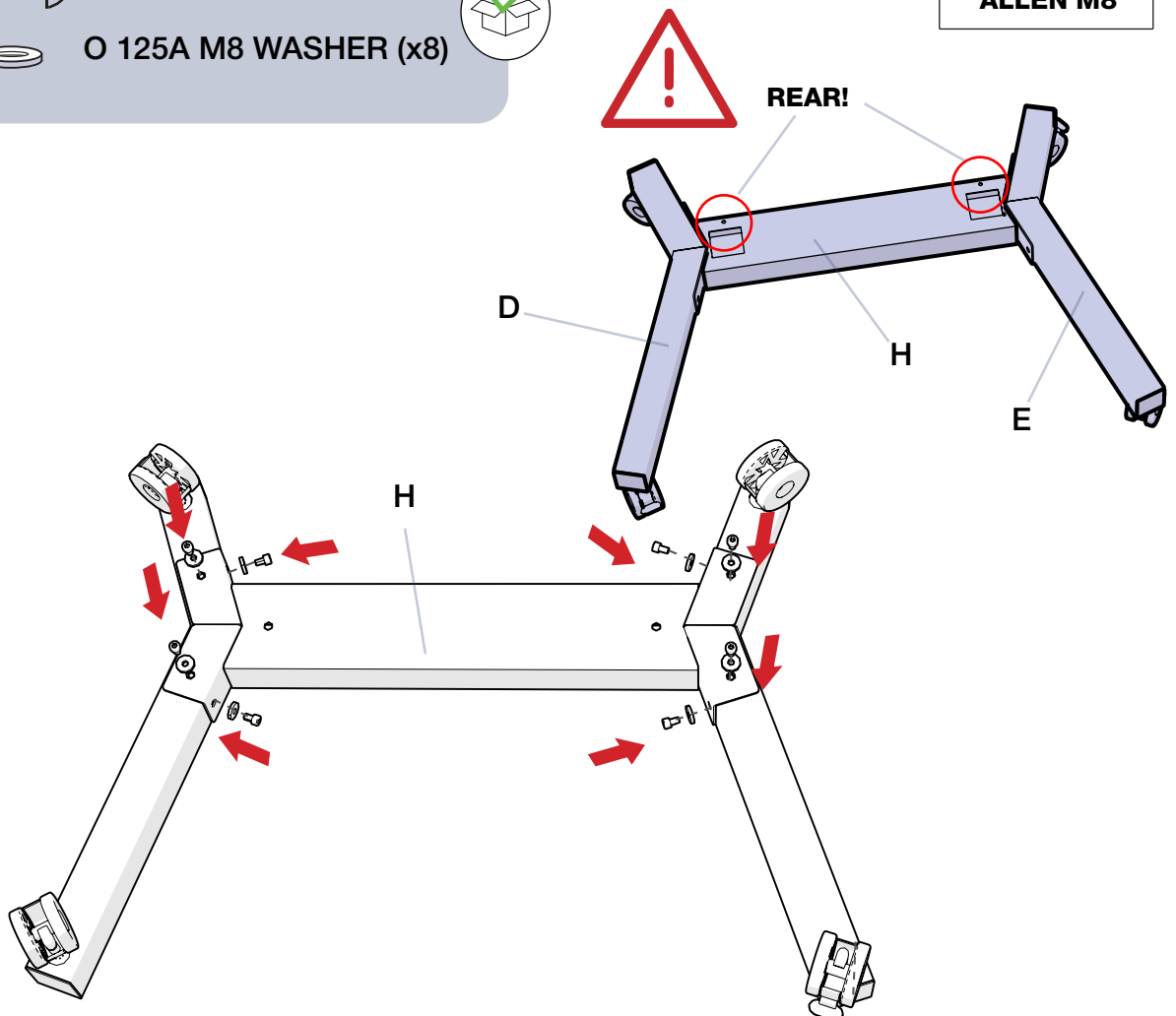

2

-  M DIN 912 M8x20 ( x8)
-  O 125A M8 WASHER (x8)



3

-  M DIN 912 M8x20 (x2)
-  L DIN 912 M10x30 (x2) 
-  N 125A M10 WASHER (x2)

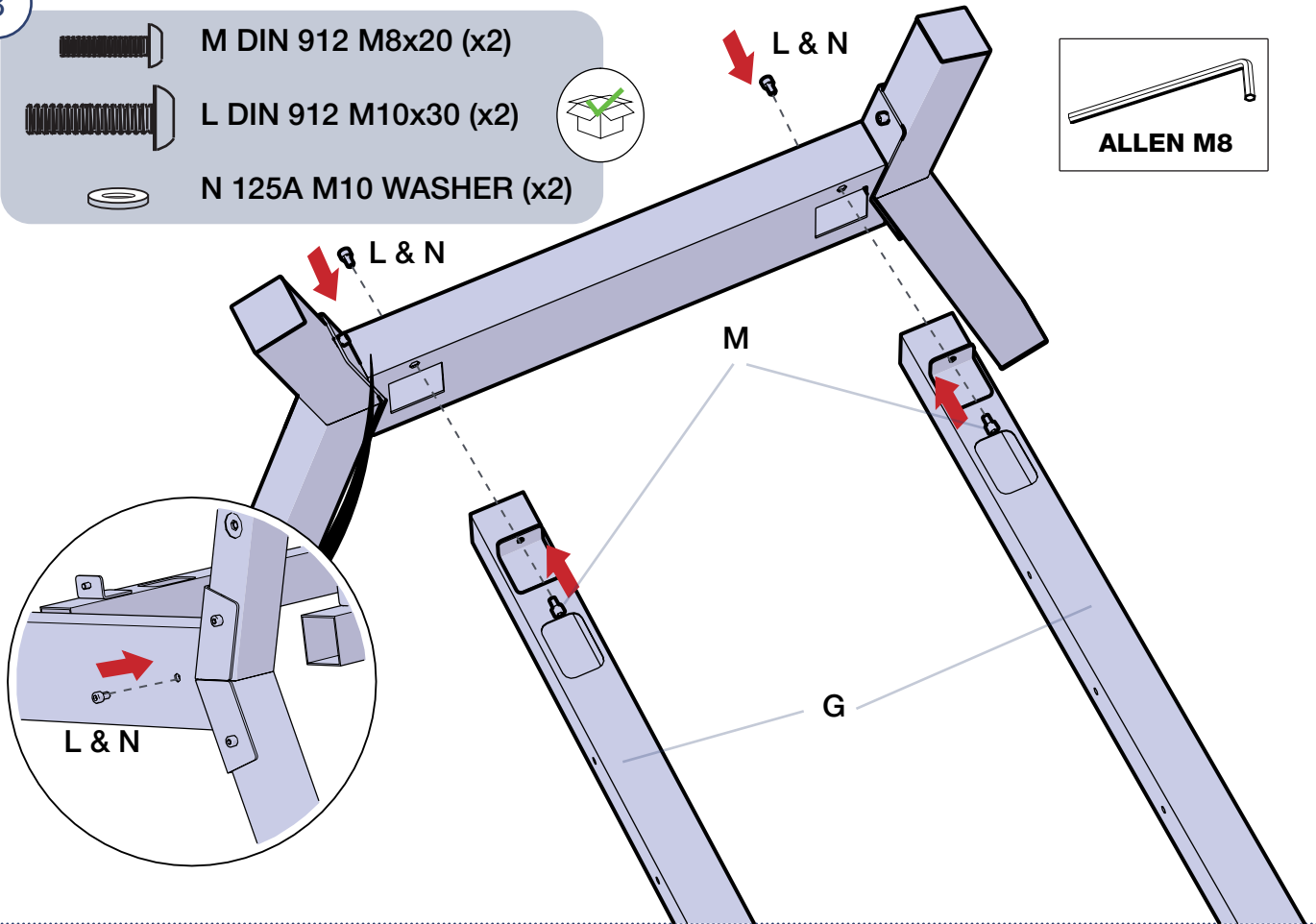

4

*HEIGHT?*  
*¿ALTURA?*

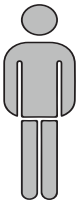

**A: 1**

**B: 2**

**C: 3**

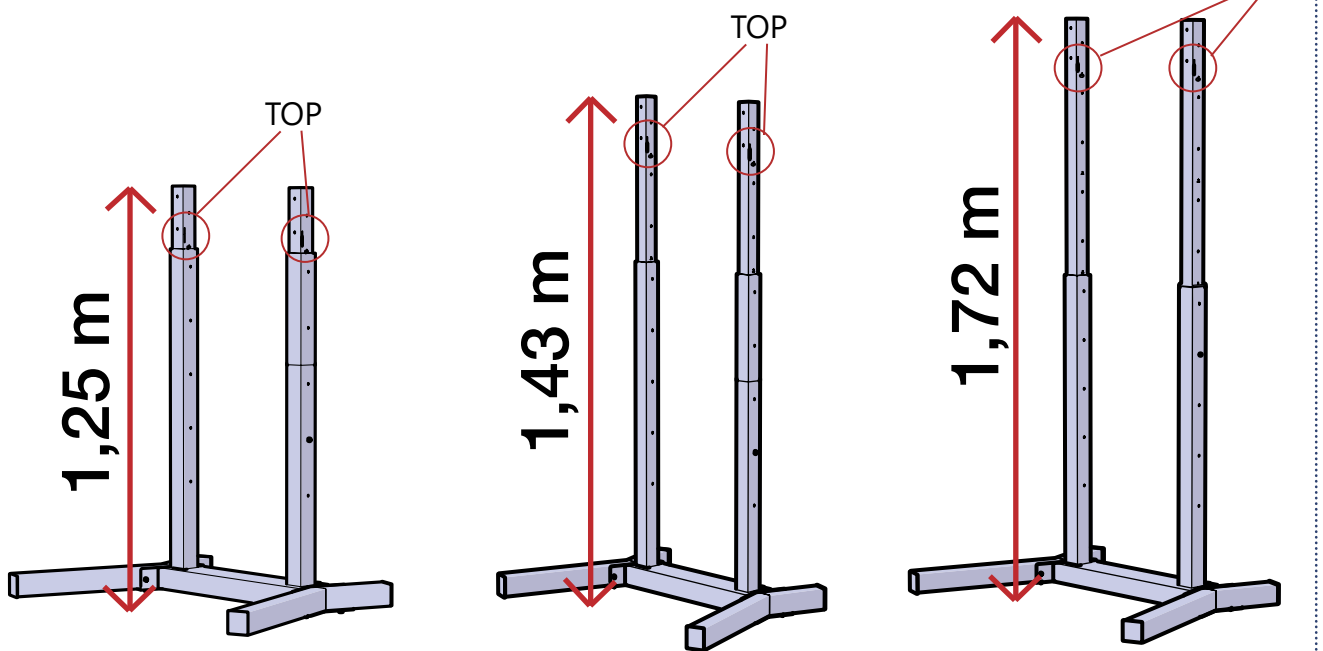

MORE AVAILABLE POSITIONS EVERY 15 CMS

5



P SELFLOCKING NUT M8 (x4)



K DIN 912 M8x80 (x4)



N 125A M8 WASHER (x8)

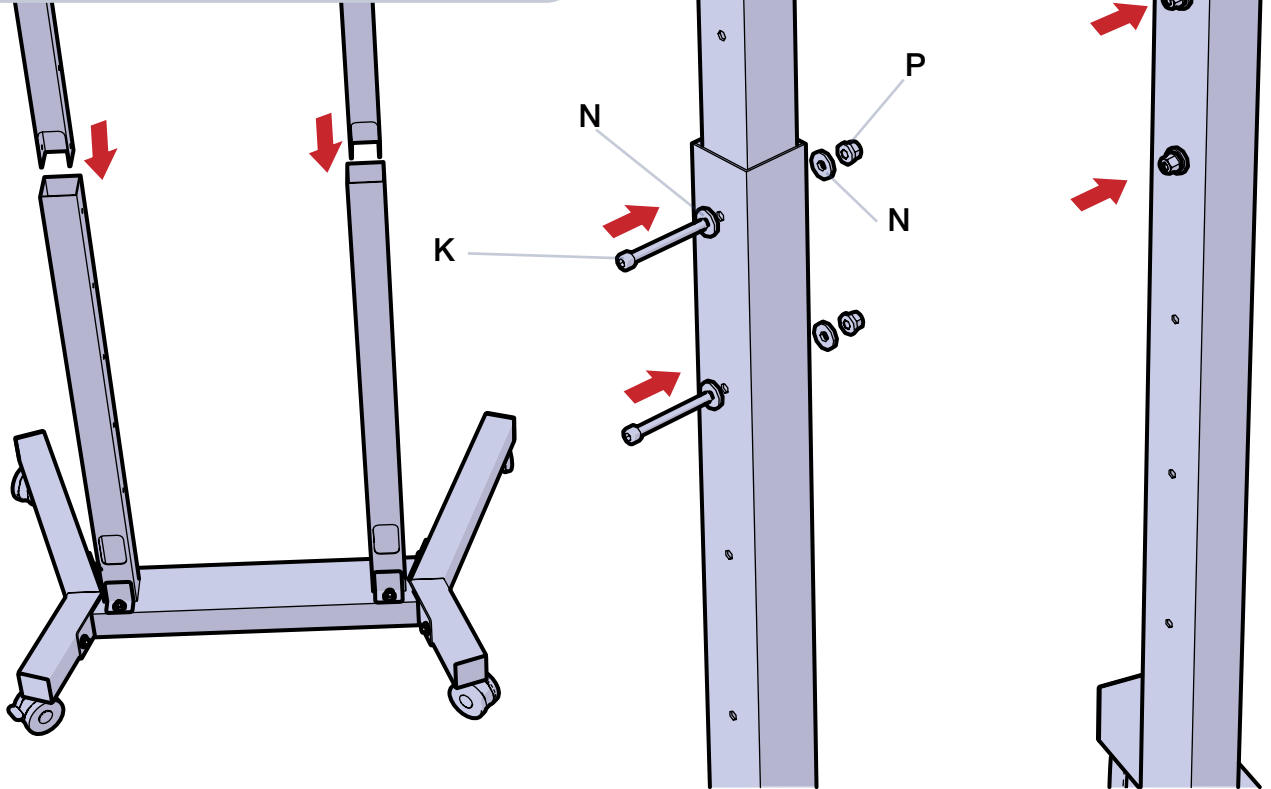

6



FRONT

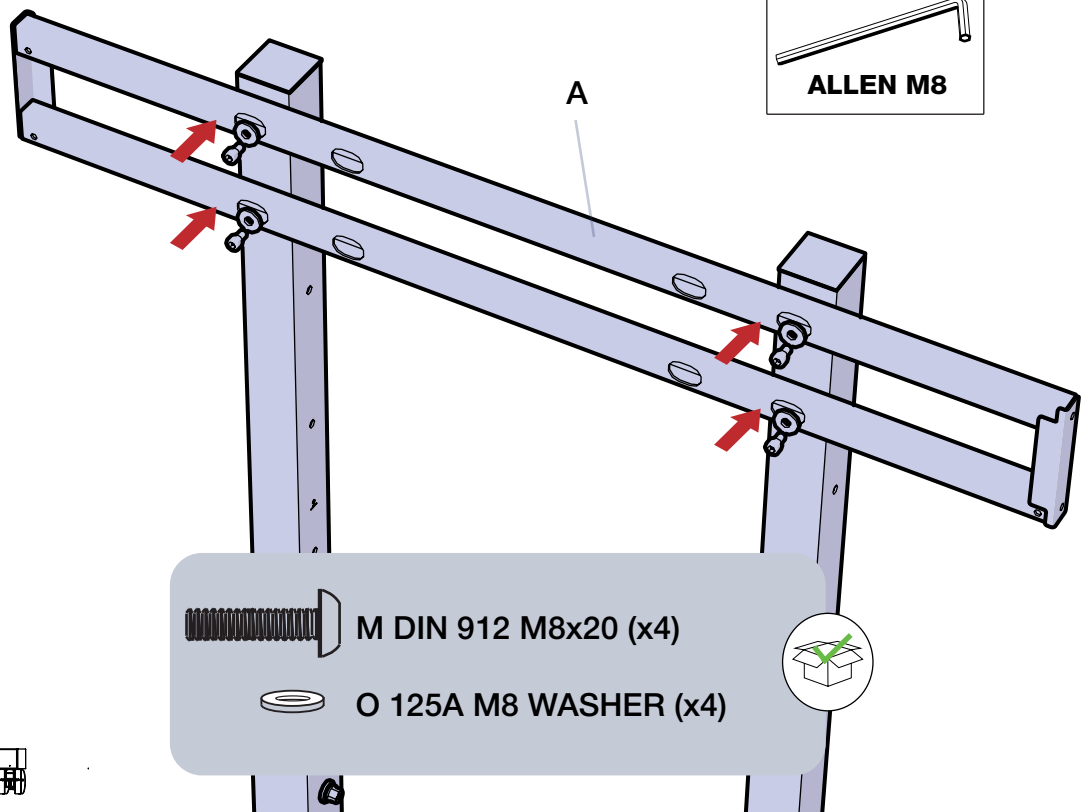

M DIN 912 M8x20 (x4)



O 125A M8 WASHER (x4)





7

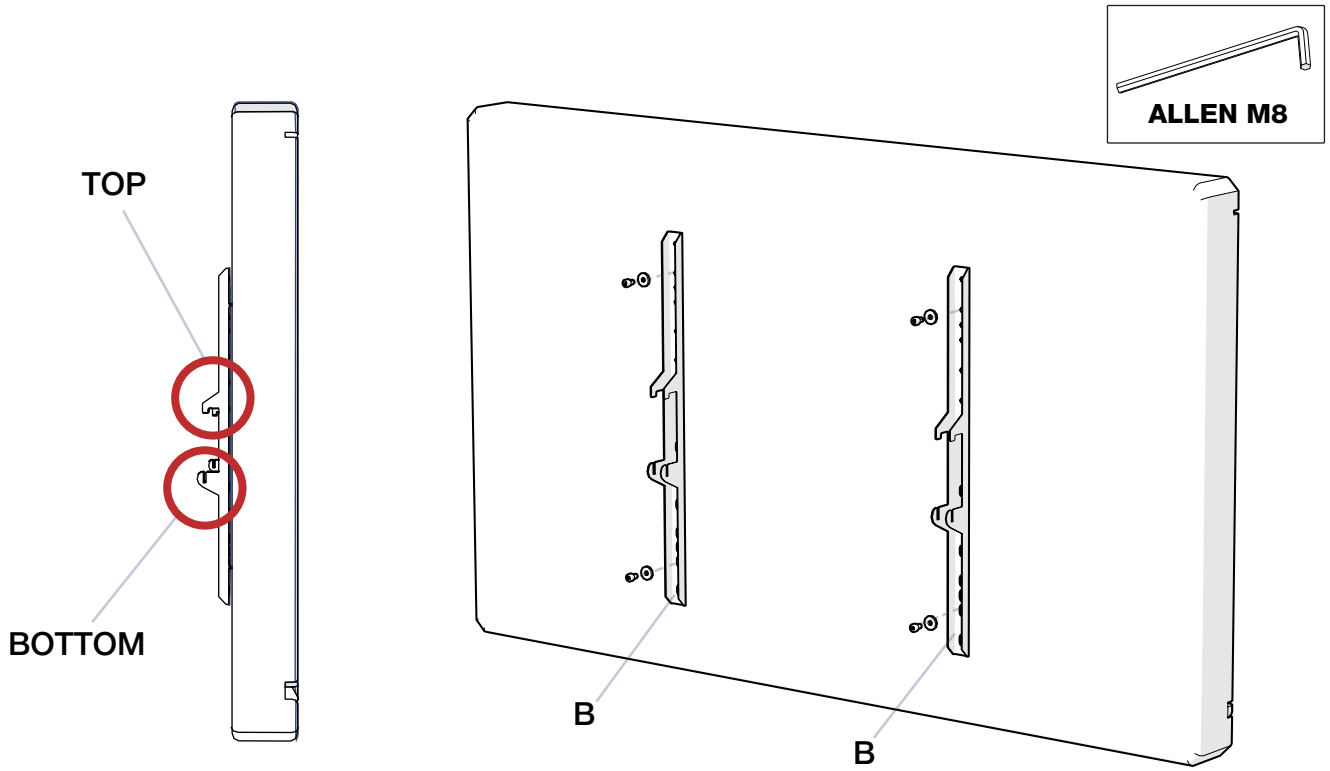

8

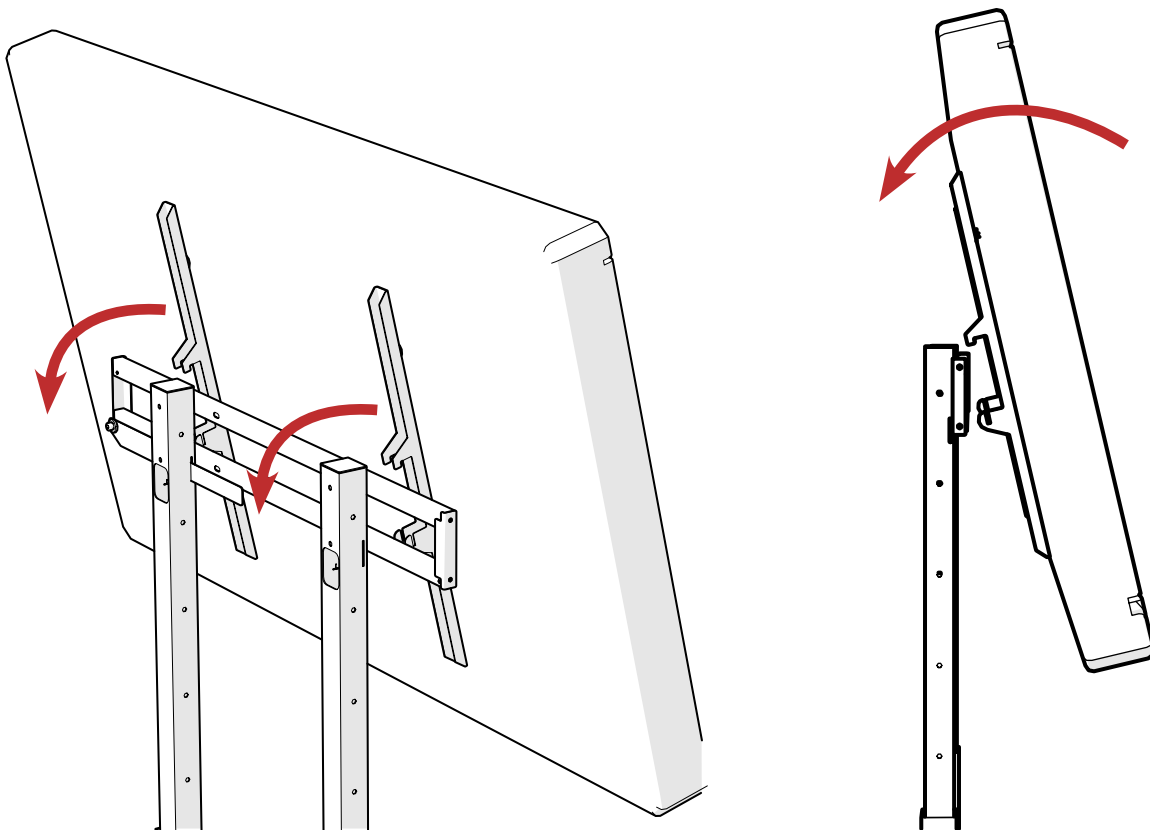

9

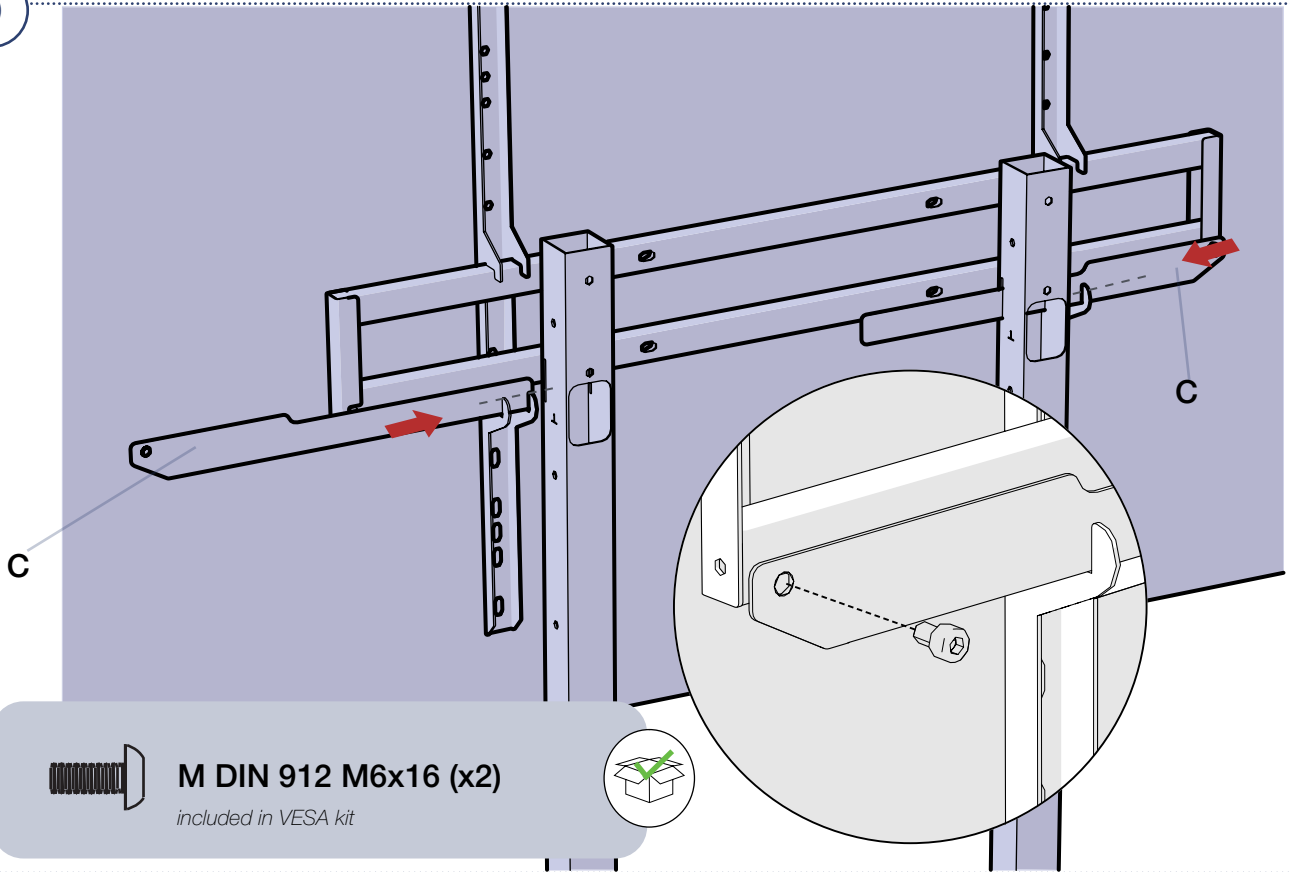

10

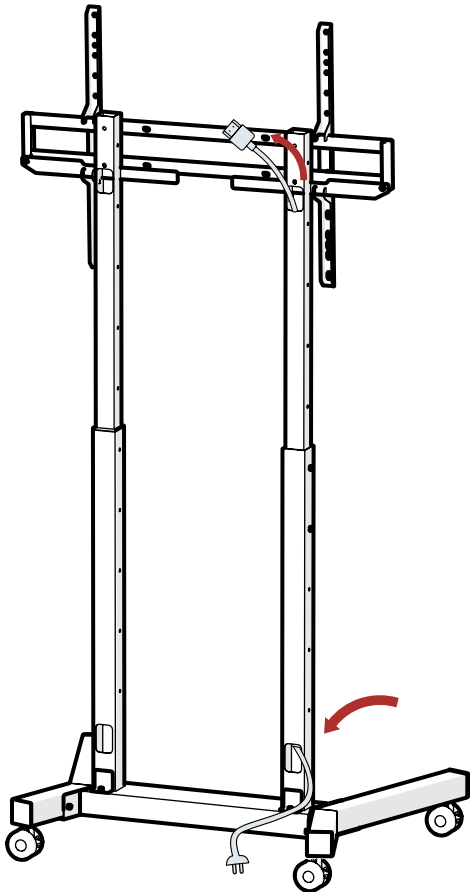

**ACCESORY: MI SHELF // ACCESORIO: MI SHELF**

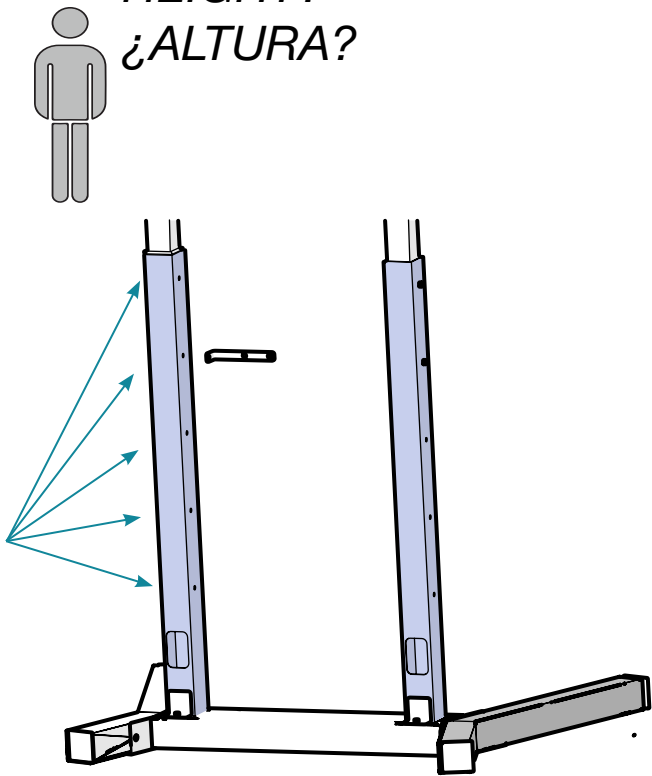

1 **HEIGHT?**  
**¿ALTURA?**

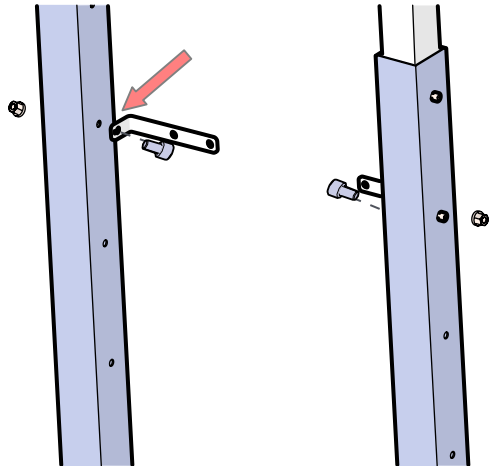

2



**ALLEN M8**



-  **SELF-LOCKING NUT M8 (x2)**
-  **DIN 912 M8x80 ( x2)**
-  **125A M8 WASHER (x4)**

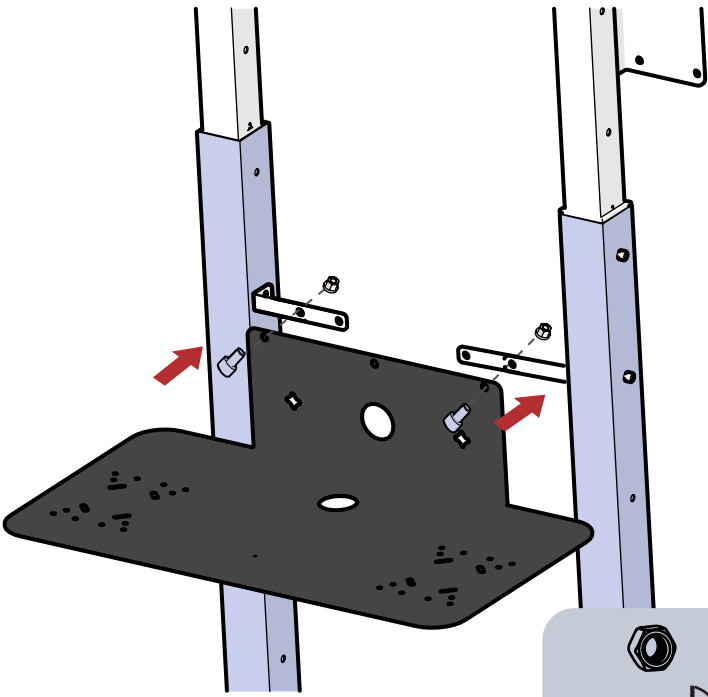

3



**ALLEN M8**

-  **SELF-LOCKING NUT M8 (x2)**
-  **DIN 912 M8x20 ( x2)**
-  **WASHER 125A M8 (x4)**



*Traulux es una marca registrada por Charmex Internacional, S.A.*

*CHARMEX INTERNACIONAL, S.A.  
C/ Maresme 103-105 - 08019 Barcelona (Spain)*

*C/ Miguel Faraday, 20 - 28906 Getafe (Madrid, Spain)  
Parque Empresarial La Carpetania*

*[www.traulux.net](http://www.traulux.net)  
[www.charmex.net](http://www.charmex.net)*

**traulux**