

GIANTSCREEN ELECTROL

SUGGESTED SPECIFICATIONS

Electrically operated projection screen 230 volt (50Hz) with a usage of no more than 1.04 Ampere. The motor is mounted inside the roller, 4 wire, 17 rotations per minute, maintenance free, integrated brake and thermal overload cut-out. The end positions are pre-set. The 4 wire connection (100 cm) is pre-installed and goes through the anodised aluminium casing and can easily be connected to an electric installation. The bottom of the casing is standard open and can optionally be delivered in a closed version. Suitable for wall and ceiling mounting with the supplied flexible mounting brackets. The screen fabrics are flame retardant. Standard 3 position wall switch is supplied. The projection screen is tested and monitored by the TÜV/GS programme (EN 60335-1 and EN 60335-2-97) and CE marked and satisfies the strictest quality and safety requirements.

SCREEN SURFACES

Matte White; Gain 1.0, viewing angle 100°, Flame retardant, max. height 500 cm, max. width 700 cm.
 Matte White Sound; Gain 1.0, viewing angle 100°, Flame retardant, max. height 500 cm, max. width 700 cm.
 Rear projection; Gain 0.5, viewing angle 60°, Flame retardant, max. height 500 cm, max. width 700 cm.

DIMENSIONS (SELECT ONE OF OUR STANDARD SIZES AND ENTER THE REQUIRED QUANTITY)

Aspect Ratio	Screen Size	Case		Weight	Screen Surfaces		
	h x w cm	L1 (mm)	L2 (mm)	in kg	Matte White	Matte White Sound	Doorzicht
4:3	450 x 600	6200	6080	142			
16:10	375 x 600	6200	6080	144			
	407 x 650	6700	6580	153			
	438 x 700	7200	7080	163			
	500 x 600	6200	6080	147			
	500 x 700	7200	7080	168			

CUSTOM SOLUTIONS

Give exact the sizes of the projection screen you need:
 Viewing size: _____ Height (cm.) x _____ width (cm.)

Motor positioned on right side

Remarks: _____

www.projectascreens.com/screendesigner

ACCESSORIES FOR OPERATION

- Easy Install RF remote control (868,3 Mhz)
 - Easy Install wireless projectorcoupling (868,3 Mhz)
 - Easy Install wireless RF wall switch (868,3 Mhz)
- Easy Install RF remote control with projectorcoupling (868,3 Mhz)
- Easy Install projectorcoupling with cable (868,3 Mhz)
- Easy Install IR remote control (868,3 Mhz)
- Easy Install plug & play relaybox with potential free contacts (868,3 Mhz)
 - Easy Install plug & play RS232/RS422 control kit
 - Easy Install plug & play RS232/RS422 with IP control kit
- Keyswitch

DIMENSIONS

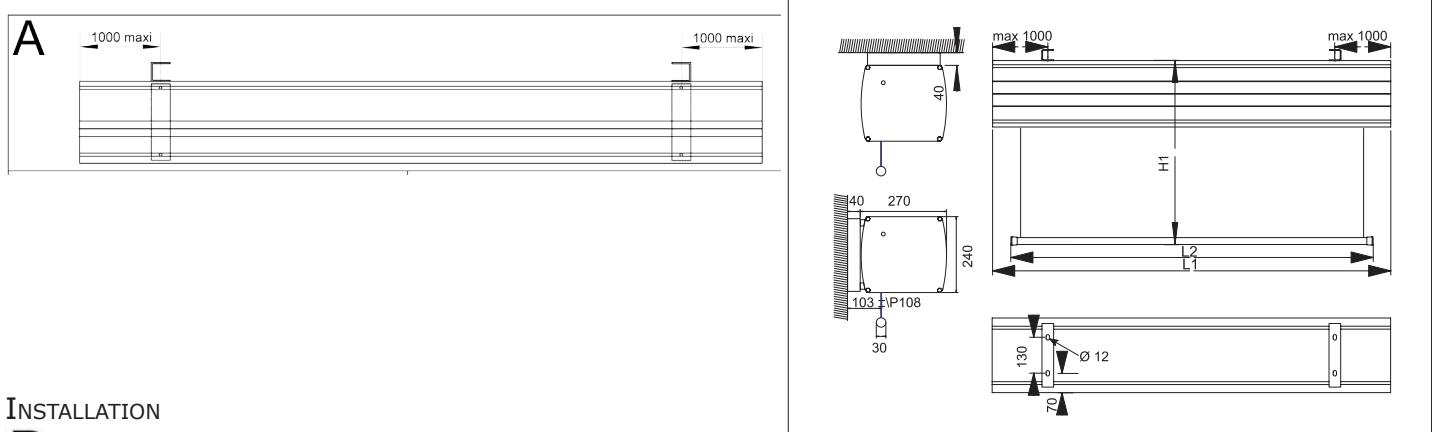

INSTALLATION

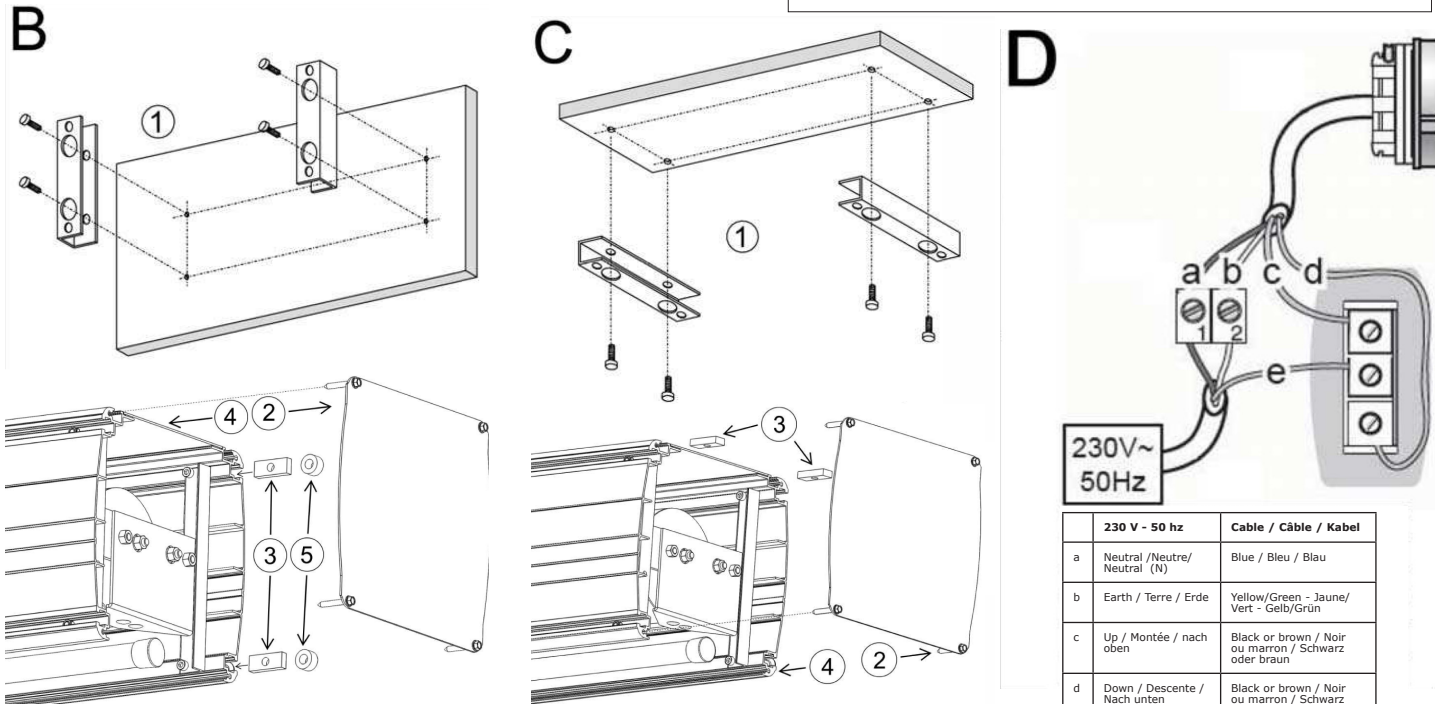

Project: _____

Architect: _____

Phone: _____

Contractor: _____

Phone: _____

Supervisor: _____

Phone: _____

Supplier: _____

Date: _____

Revised: _____